

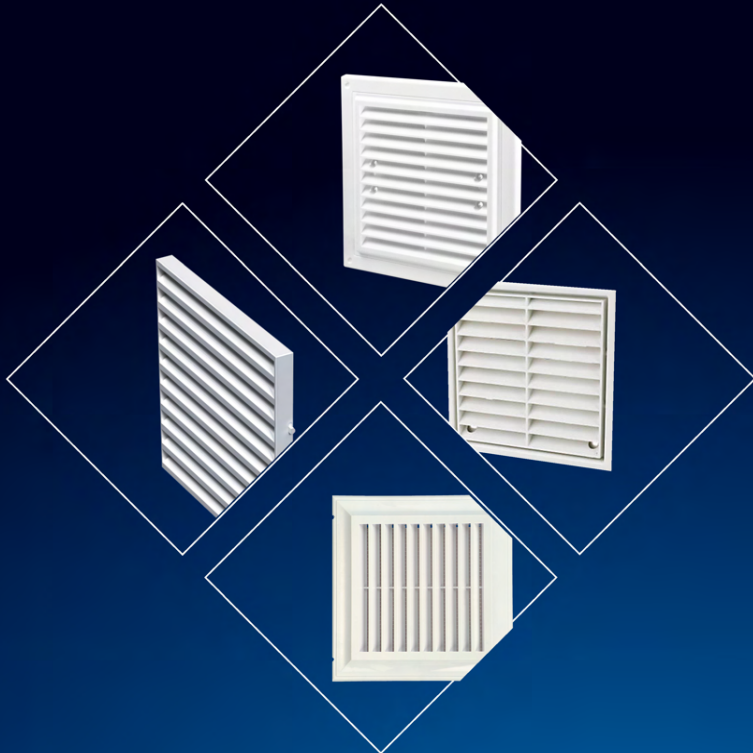

Global Air



Exhaust & Air Louvers

EXHAUST AND AIR LOUVERS

CONTENTS

- | | |
|----|--|
| 01 | Introduction, Features & Characteristics. |
| 02 | Models, Exhaust Air Louvers. |
| 03 | Models, Fresh Air Louvers. |
| 04 | Profiles used In Exhaust & Fresh Air Louvers, Available Fixing Mounting. |
| 05 | Effective Area Values for Exhaust and Fresh Air Louvers. |
| 06 | Tabular Selection for Exhaust and Fresh Air Louvers |
| 07 | Air Flow Resistance Diagram, Selection Procedure. |
| 08 | Ordering Data. |

Engineering Notes:

→ The Aluminium Exhaust and Fresh Air Louvers of Our Company are used both internally and externally in buildings for the extraction of re-cycled air, intake of external fresh air or the expulsion of contaminated air. The quality of the material used and the particular inclination of the blades at 60° angle downward offer a weather resistant

Louvers which gives good protection against the direct ingress of rain water, leaves and birds. Can also be used directly installed on walls for the ventilation of industrial areas. Also suitable for the use with an adjustable or overpressure damper for air flow and pressure control.



Features & Characteristics:

- Construction: Frame & Blades are made of high quality Extruded Aluminium Profiles of 6063 Alloy.
- Frame Flange width: 30 mm.
- Blades: Fixed Louverd type arranged horizontally and inclined downward to 60 degree angle in order to:
 - prevent the ingress of rain water.
 - Prevent the ingress of light.
 - Block vision while straight viewing.
 - Be suitable for external walls and screening applications.
- The blades are positioned on 25 mm minimum centers up to 35 mm maximum centers resulting in a high free area to provide minimum resistance to air flow.
- Available in wide variety of neck sizes with 1 00 x 1 00 mm minimum single section size and 2 mtr maximum single section height. Louvers height exceeding 2 mtr to be fabricated and supplied in multiple sections depending on length and height dimensions as well as site conditions.
- The assembly of multiple sections is unlimited, where each section operates independently.
- Multiple sections: Supplied as separate sections and assembly by others on site.
- The Fresh Air Louver is suitable for the use in air inlet of fresh air ducts and air handling units. It's also suitable for the use at dirty air exhaust discharge.
- Wire Mesh screen of galvanized steel is attached to the interior face of the louver as an option, mesh size 3 x 3 mm.
- Exhaust Air Louvers are available with different type of attachments such as:
 - Opposed Blade Damper (Model EAL +D).
 - Aluminium Filter (Model FAL c/w Filter).
 - Both the Damper and Filter (Model FAL + D c/w Filter).
- Available with Foam type Rubber Gasket for air sealing (provided as an option).
- Mounting instructions: see page No. EL-04
- Surface Finishes: see page No. EL-08.

Exhaust Air Louvers

Construction and Dimensional Details

➔ Model EAL

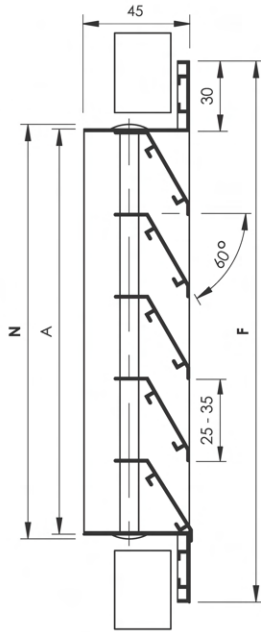

➔ Model EAL + D (Double Frame)

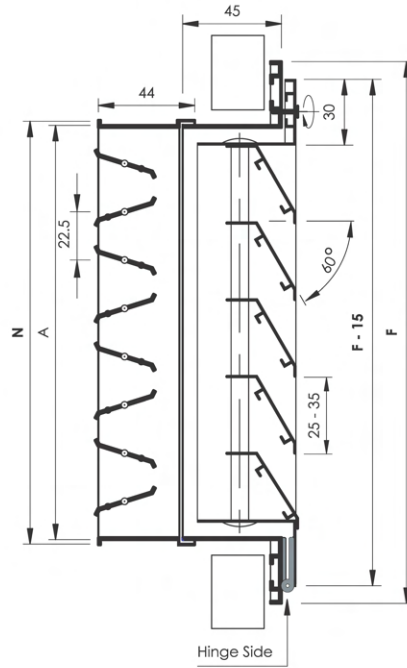

N : Nominal/Listed Size = Length (L) x Height (H)
A : ActualSize = (L-10) x (H-10)
F : Face Size = (L+50) X (H+50)

- Exhaust Air Louvers furnished approximately 10 mm less than the NominaVListed Size.
- AllDimensions are in mm and subject to:t1 mm tolerance
- Exhaust Air Louvers furnished approximately 10 mm less than the NominaVListed Size.
- AllDimensions are in mm and subject to:t1 mm tolerance

Model EAL

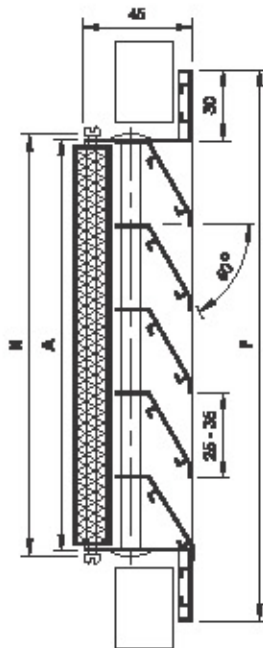

- Wire Mesh (optional).
- Filter : Aluminium Washable Filter Media of 1/2 « standard thickn ss 11» & 2» thicknesses also available on request as
- an option.



N : Nominal/Listed Size = Length (L) x Height (H)
A : Actual Size = (L-10) x (H-10)
F : Face Size = (L+50) x (H+50)

- Exhaust Air Louvers furnished approximately 10 mm less than the Nominal/Listed Size.
- All Dimensions are in mm and subject to ± 1 mm tolerance.

Model FAL + D c/w Filter (Double Frame)

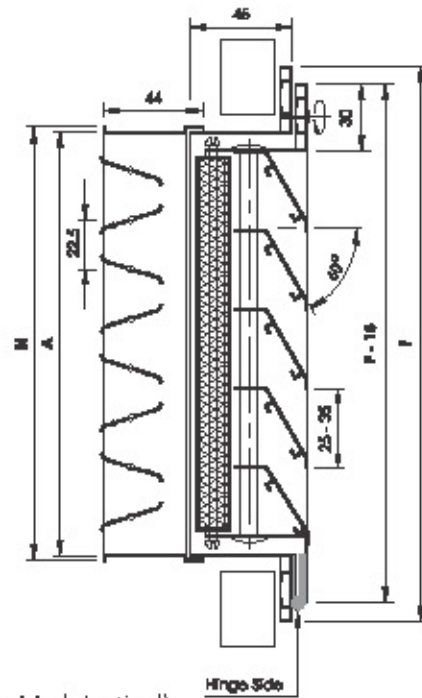

- Wire Mesh (optional).
- For Opposed Blade Damper details and construction refer to chapter (1) or (2).
- Filter : Aluminium Washable Filter Media of 1/2 « standard thickness (1) & 2» thicknesses also available on request as an option).
- Double Frame Louvers are provided with door hinge from one side and screw from other side allowing the second frame (inner one) to act as an access door to the Filter and I or Opposed Blade Damper.



Cross Sectional Drawings for Profiles used in Exhaust and Fresh Air Louvers

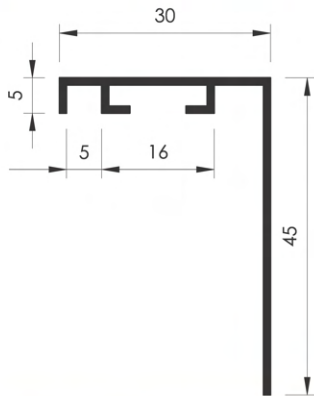

Frame Profile Section
Exhaust and Fresh Air Louvers

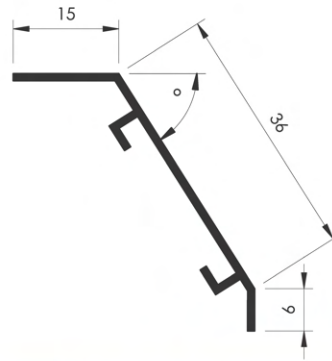

Louver Blade Profile Section
Exhaust and Fresh Air Louvers

- All Dimensions are in mm and subject to ± 0.2 mm tolerance.

Available Fixing Mounting

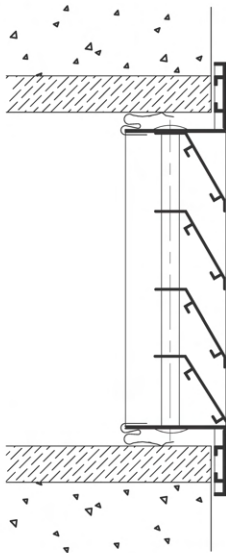

A. Concealed Fixing (Spring Clip Mounting)

The Louver is fixed by means of spring clips to the wall or partition where no screws are visible.

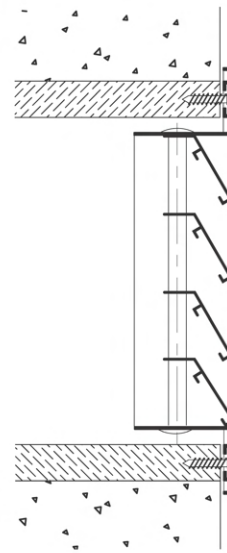

B. Face Screw Fixing

The Louver is fixed to the wooden frame by means of visible screws.

EFFECTIVE AREA VALUES FOR EXHUAUST AND FRESH AIR LOUVERS IN (m²)

L	H	100	150	200	250	300	350	400	450	500	550	600
100		0.004										
150		0.006	0.009									
200		0.008	0.012	0.016								
250		0.010	0.015	0.021	0.026							
300		0.012	0.018	0.025	0.031	0.037						
350		0.016	0.024	0.032	0.039	0.047	0.055					
400		0.018	0.027	0.036	0.045	0.054	0.063	0.072				
450		0.020	0.030	0.041	0.051	0.061	0.071	0.081	0.091			
500		0.025	0.038	0.050	0.063	0.075	0.088	0.100	0.113	0.125		
550		0.028	0.041	0.055	0.069	0.083	0.096	0.110	0.124	0.138	0.151	
600		0.033	0.050	0.066	0.083	0.099	0.116	0.132	0.149	0.165	0.182	0.198
650		0.036	0.054	0.072	0.089	0.107	0.125	0.143	0.161	0.179	0.197	0.215
700		0.041	0.061	0.081	0.102	0.122	0.142	0.162	0.183	0.203	0.223	0.244
750		0.044	0.065	0.087	0.109	0.131	0.152	0.174	0.196	0.218	0.239	0.261
800		0.048	0.072	0.096	0.120	0.144	0.168	0.192	0.216	0.240	0.264	0.288
850		0.051	0.077	0.102	0.128	0.153	0.179	0.204	0.230	0.255	0.281	0.306
900		0.057	0.085	0.113	0.142	0.170	0.198	0.227	0.255	0.284	0.312	0.340
950		0.060	0.090	0.120	0.150	0.180	0.209	0.239	0.269	0.299	0.329	0.359
1000		0.065	0.098	0.130	0.163	0.195	0.2289	0.260	0.293	0.325	0.358	0.390
1050		0.068	0.102	0.137	0.171	0.205	0.239	0.273	0.307	0.341	0.375	0.410
1100		0.068	0.107	0.143	0.179	0.215	0.250	0.286	0.322	0.358	0.393	0.429
1150		0.075	0.112	0.150	0.187	0.224	0.262	0.299	0.336	0.374	0.411	0.449
1200		0.078	0.117	0.156	0.195	0.234	0.273	0.312	0.35	0.390	0.429	0.468

TABLE EL-02

L	H	650	700	750	800	850	900	950	1000	1050	1100	1150	1200
650		0.232											
700		0.264	0.284										
750		0.283	0.305	0.326									
800		0.312	0.336	0.360	0.384								
850		0.332	0.357	0.383	0.408	0.434							
900		0.369	0.397	0.425	0.454	0.482	0.510						
950		0.389	0.419	0.449	0.479	0.509	0.539	0.569					
1000		0.423	0.455	0.488	0.520	0.553	0.585	0.618	0.650				
1050		0.444	0.478	0.512	0.546	0.580	0.614	0.648	0.683	0.717			
1100		0.465	0.501	0.536	0.572	0.608	0.644	0.679	0.715	0.751	0.787		
1150		0.486	0.523	0.561	0.635	0.635	0.673	0.710	0.748	0.785	0.822	0.860	
1200		0.507	0.546	0.585	0.624	0.663	0.702	0.741	0.780	0.819	0.858	0.897	0.936

- L & H Dimensions are in mm.
- Damper at full open position (if any).

Air Flow Resistance Diagram (All Models) Pressure Drop (t.: Pt) versus Face Velocity (Vf)

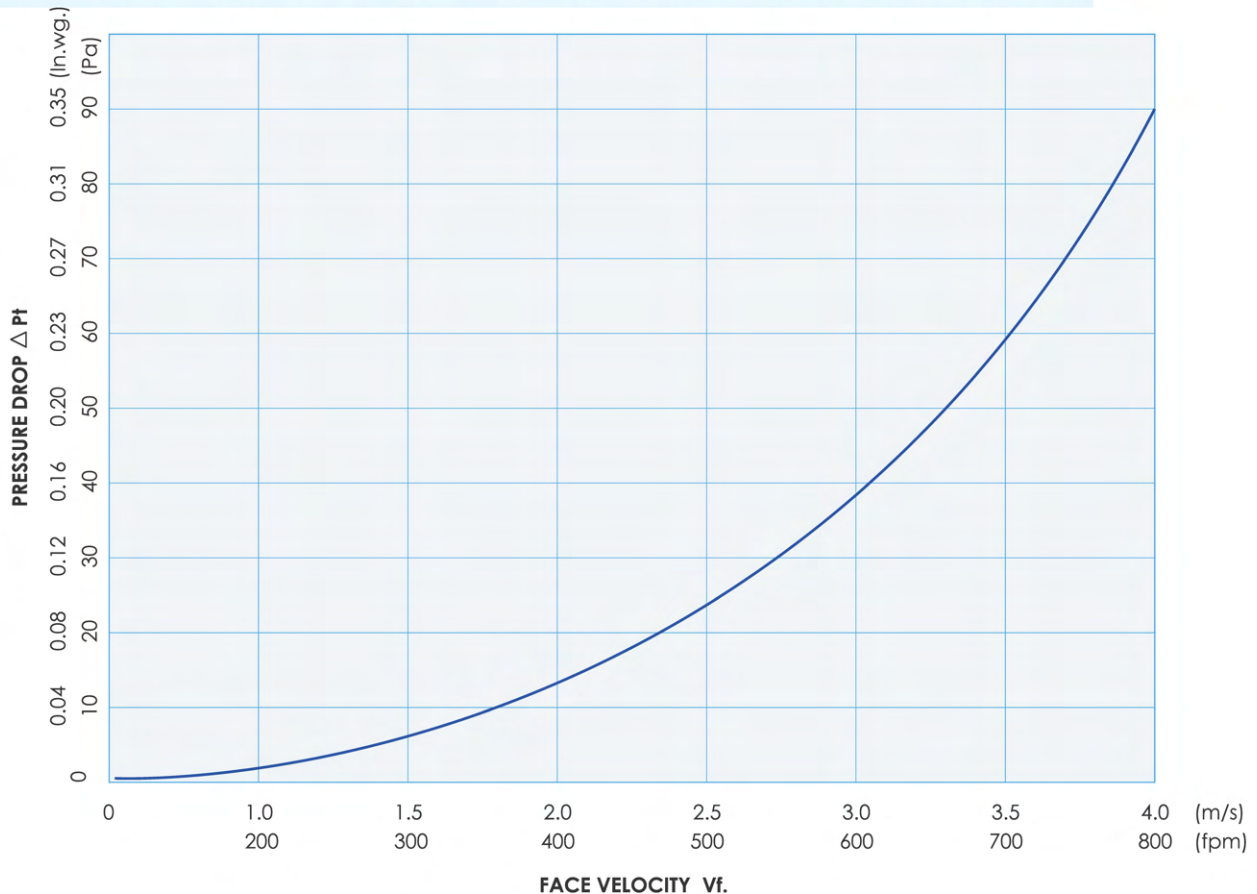

Selection Procedure

easel:

Illustrative Example :

Given Data : Required Model : EAL

Air Flow Rate : 650 CFM [307 LIS] Assume V f. not exceeding 1.5 m/s [300 FPM].

Refer to page No. EL-06 Table EL-03. @ 650 CFM and V f. = 1.5 m/s to read the related data as below :

Pressure Drop = 8.0 Po (0.031nwg) A elf. = 0.201 m²

By applying the A elf. value to table No. EL-01, simply you can select the size of 700 x 500 mm which is having the nearest area value to the required one.

easel:

Illustrative Example :

Given Data : Required Model : FAL c/W Filter

Air Flow Rate : 3500 CFM (1652 L/S) Assume V f. not exceeding 1.5 m/s [300 FPM].

Since the CFM given is out of the range of Table No.

EL-03 divide the (3500) by [2] to give 1750 CFM and read the related data at this value as below :

Pressure Drop = 8.0 Po [0.03 Inwg]

Aeff. = 0.542 m²

By applying the A elf. value to table No.EL-02, simply you can select the size of 950 x 900 mm which is having the nearest area value to the required one.

Now.to obtain the required 3500 CFM -double the area while maintaining the same height as

below : (I X 2) X (H) = (950 X 2) X (900) mm

Finalsize= 1900 x 900 mm.

Ordering Data

Available Surface Finishes For Exhaust And Fresh Air Louvers:

- Natural | Matt Silver Anodized.
- Powder Coating (Standard Colors are white RAL 9010 | 9016. other optional colors if required to be provided in RAL- No. only and charged extra).
- Aluminium in Mill Finish.
- Other Special finishes (on request if available).

Available Surface Finishes For Opposed Blade Damper:

- Aluminium in Mill Finish (standard).
- Matt Black Powder Coating (optional).

Specify:

1. Louver Description | Model (Exhaust or Fresh, with or w/o Opposed Blade Damper).
2. Wire Mesh (only mention if required).
3. Nominal / Neck Size
4. Quantity.
5. Exhaust | Fresh Air Louvers Surface Finish.
6. RAL- No. (Only mention if powder coating surface finish is required).
7. Type of Fixing (Concealed or Face Screw Fixing).
8. Thickness of Aluminium Filter for Fresh Air Louvers (only mention if optional 1 or 2» thickness is required).
9. Rubber Gasket (only mention if required).
10. Remarks if any.

Example 1:

1	2	3	4	5	6	7	8	9	10
EAL	+WM	8" x 8" 200 x 200 (mm)	25	Mill	-	Concealed	-	-	-

Example 2:

1	2	3	4	5	6	7	8	9	10
FAL c/w Filter	-	16" x 10" 400 x 250 (mm)	7	Powder Coating	1013 (Optional)	Screw	-	With Rubber Gasket	-

Example 3:

1	2	3	4	5	6	7	8	9	10
FAL c/w Filter + D	-	30" x 20" 750 x 500 (mm)	15	Silver Anodized	-	Concealed	2" (Optional)	-	(Double Frame)

Gravity Louvers GL and Non Return Dampers

CONTENTS

- 01 Introduction, Features & Characteristics.
- 02 Models, Gravity Louvers.
- 03 Models, on Return Dampers.
- 04 Profile used In Gravity Louvers, Mullion Arrangement for Gravity Louvers, Available Fixing Mounting.
- 05 Air Flow Resistance Diagram, Air Flow Rate Calculation.
- 06 Tabular Selection for Gravy Louvers and Non Return Dampers.
- 07 Tabular Selection for Gravity Louvers and Non Return Dampers.
- 08 Ordering Data.

Engineering Notes:

→ Gravity Louvers GL and Non Return Dampers NRD are generally used in intake and discharge applications in residential, commercial and industrial ventilated systems. GLs and NRDs guarantee that the automatic opening of the blades will occur when the fan or system is switched on and equally will close when switched off in order to avoid passage of air when the system is closed, i.e. preventing the reverse of air flow. They are also used to maintain certain pressure in pressurized treated areas with respect to others, thus only when pressure is exceeding the designed

limit, blades will automatically open to discharge or relieve the excessive air.

GLs and NRDs are also commonly named as «Pressure Relief Dampers», «Over Pressure Dampers», «Back Draft Dampers» or «Gravity Shatters» according to the purpose of their use.

→ Features & Characteristics

Gravity Louvers (GL):

- Frame construction: made of high quality Extruded Aluminium Profiles of 6063 Alloy.
- Frame Flange width: 30 mm.
- Blades: fabricated from Aluminium sheet of 0.5 mm thickness.
- Aluminium Blades are fixed to the frame through a galvanized steel rods (axles) for rigid construction.
- Aluminium Blades are fitted with nylon bushes for corrosion resistance, rattle free and smooth operation.
- The blades are positioned on 45 mm minimum centers up to 100 mm maximum centers resulting in a high free area to provide minimum resistance to air flow.
- Available in wide variety of neck sizes with 100 x 100 mm minimum single section size and 2 mtr maximum single section height. Louvers height exceeding 2 mtr to be fabricated and supplied in multiple sections depending on length and height dimensions as well as site conditions.
- The assembly of multiple sections is unlimited where each section operates independently.
- Multiple sections: Supplied as separate sections and assembly by others on site.
- Usually used for external or internal wall mounting installations.

Non Return Dampers (NRD) :

- Casing construction: made of 18 or 20 gauge formed galvanized steel sheet.
- Casing Flange width: 25 - 30 mm (Model NRD- F).

- Blades: fabricated from Aluminium sheet of 0.5 mm thickness in mill finish.
- Aluminium Blades are fixed to the frame through galvanized steel rods (axles) for rigid construction.
- Aluminium Blades are fitted with nylon bushes for corrosion resistance, rattle free and smooth operation.
- The blades are positioned on 50 mm minimum centers up to 100 mm maximum centers resulting in a high free area to provide minimum resistance to air flow.
- Available in wide variety of neck sizes with 100 x 100 mm minimum single section size and 2 mtr maximum single section height. Louvers height exceeding 2 mtr to be fabricated and supplied in multiple sections depending on length and height dimensions as well as site conditions.
- All joints are welded and sealed for air tight operation and protected by Aluminium spray paint.
- Available in 3 types I models according to casing design. Slip, Clip and Flange type as shown in page No. GL-03.
- Usually used for duct mounting installations.
- Automatically, when the duct pressure is normalized, the blades drop to closed position by gravity effect.
- The specially designed blades have an overlapping lip which assures a tight closure while in closing position.
- Available with Foam type Rubber Gasket for air sealing (provided as an option).
- Mounting instructions: see page No.GL-04.

Gravity Louvers

Construction and Dimensional

Model GL

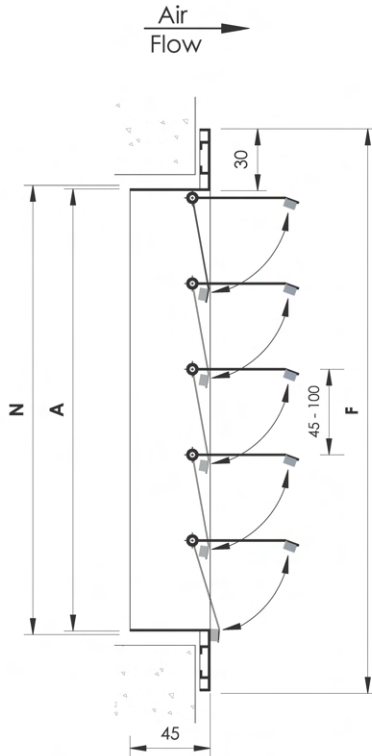

- Mounting : usually used for **External** Wall mounting installations.



Model GL-R (Reversed Blades)

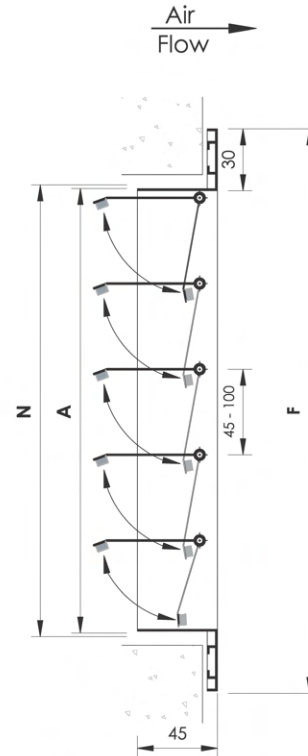

- Mounting : usually used for **Internal** Wall mounting installations with reversed blades as shown above.



N :Nominal/Listed Size = Length (L) x Height (H)
A :Actual Size = (L-10)x(H-10)
F :Face Size = (L+50) x (H+50)

- Blades are sealed at the lower end of each by foam type Rubber Gasket as a standard for air tightness while closure.
- Gravity louvers furnished approximately 10 mm less than the Nominal/Listed Size.
- All Dimensions are in mm and subject to ± 1 mm tolerance.

Non Return Dampers

Construction and Dimensional Details

Model NRD•S

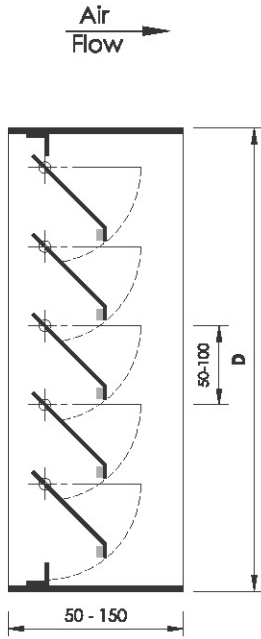

- Mounting : Usually used for duct mounting installations with open ends (**Slip type**).

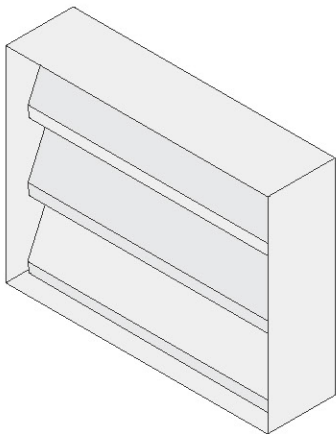

Model NRD•C

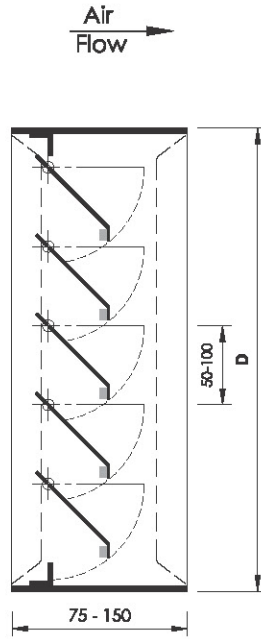

- Mounting : Usually used for duct mounting installations with cleat ends (**Clip type**).

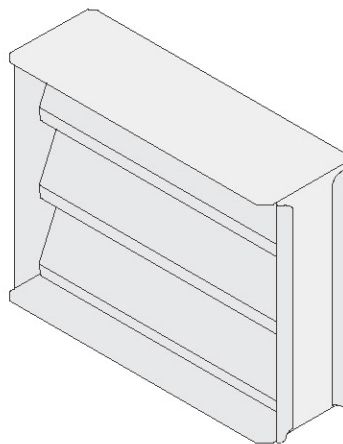

Model NRD•F

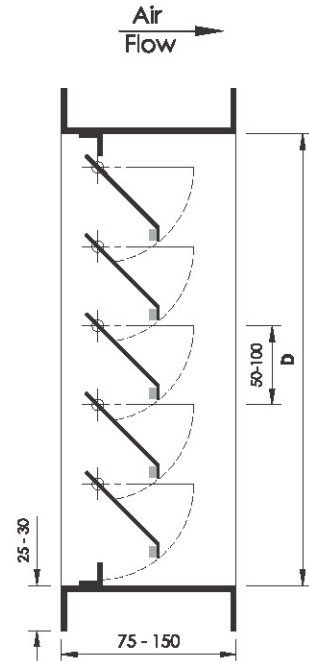

- Mounting : Usually used for duct mounting or recessed installations with flanged ends (**Flange type**).

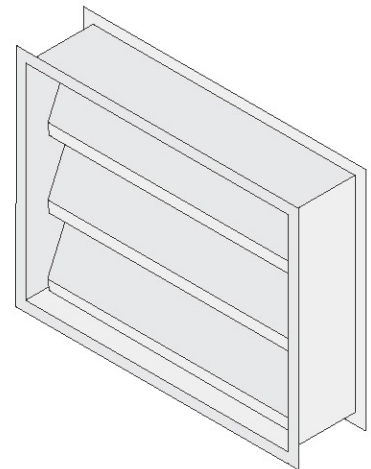

Gravity Louvers

Construction and Dimensional

Cross Sectional Drawings for Profile used In Gravity Louvers

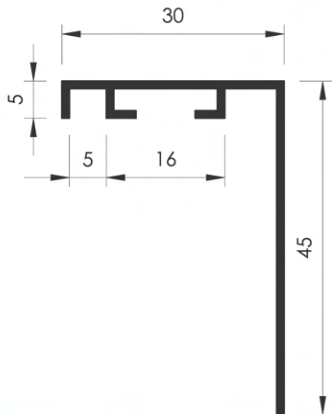

Frame Profile Section
Gravity Louvers

- All Dimensions are in mm and subject to ± 0.2 mm tolerance

Mullion Arrangement - Model GL

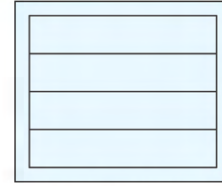

Without Mullion
 $L \leq 500$ mm

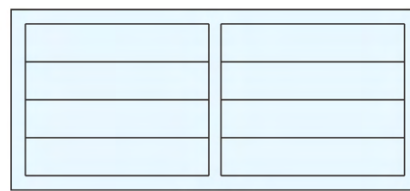

1 Mullion
 $500 \text{ mm} < L \leq 1000$ mm

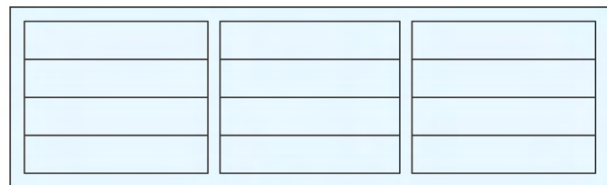

2 Mullions or more
 $L > 1000$ mm

Available Fixing Mounting - Model GL

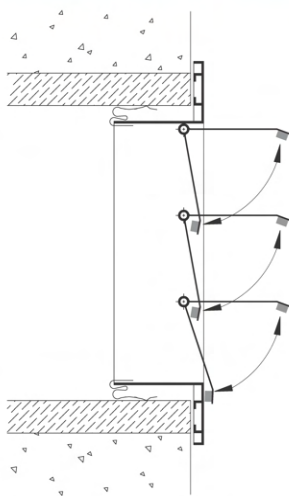

A. Concealed Fixing (Spring Clip Mounting)
The Gravity Louver is fixed by means of spring clips to the wall or partition where no screws are visible.

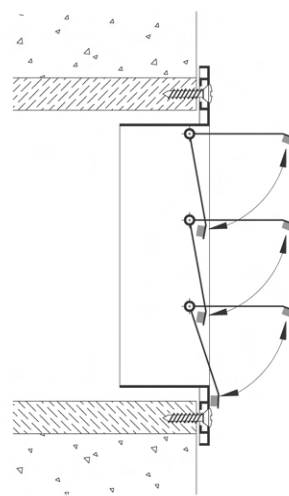

B. Face Screw Fixing
The Gravity Louver is fixed to the wall (with wooden Frame) by means of visible screws.

Air Flow Resistance Diagram (All Models) Pressure Drop (Pt) versus Face

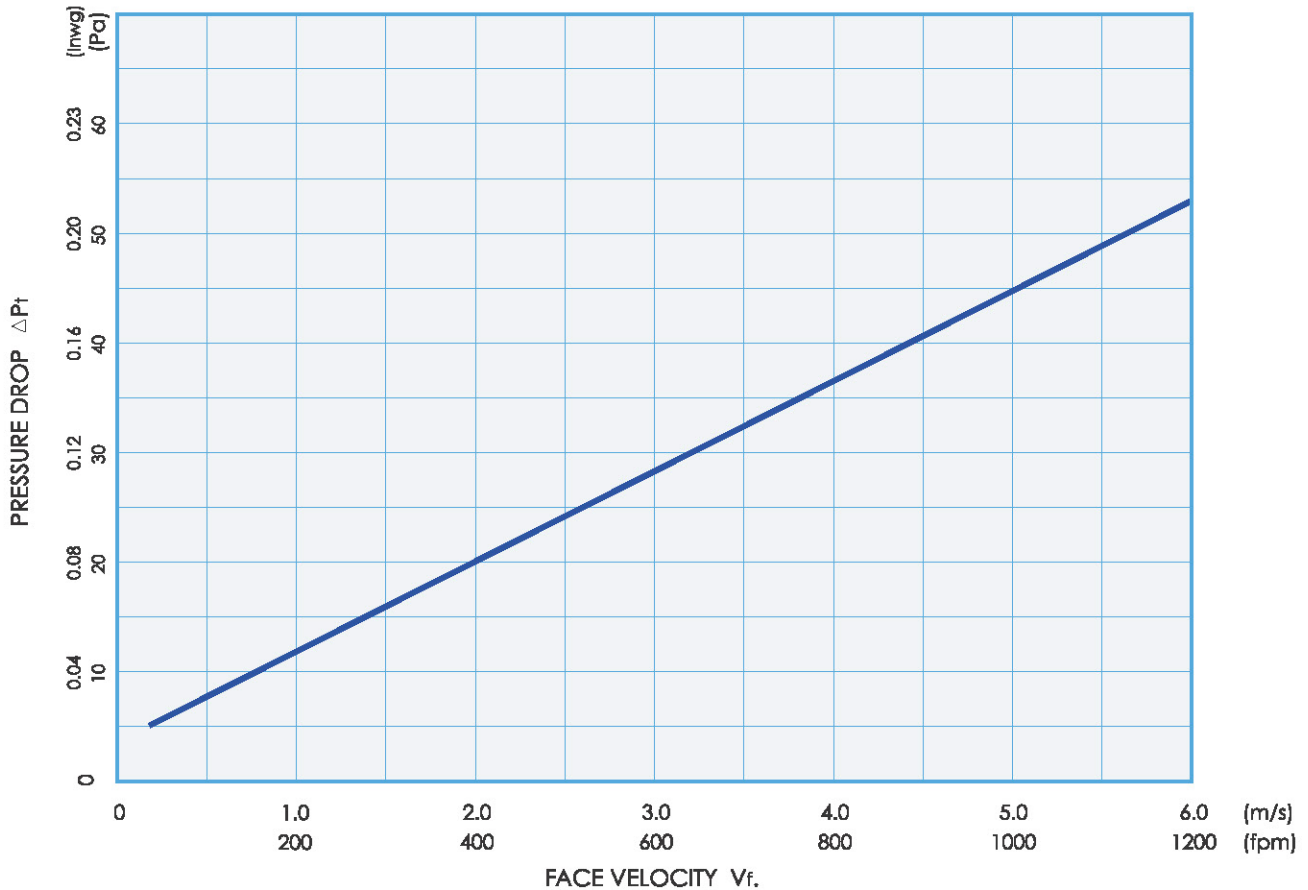

To Calculate The Air Flow Rate (All Models)

Simply the Air Flow Rate in (L/S) or (CFM) can be calculated using any of the following equations:

$$\text{Air Flow Rate in (L/S)} = 0.80 \times \frac{L \text{ (mm)} \times H \text{ (mm)} \times V_r \text{ (m/s)}}{1000}$$

$$\text{Air Flow Rate In (CFM)} = 0.80 \times \frac{L \text{ (Inch)} \times H \text{ (Inch)} \times V_r \text{ (fpm)}}{151}$$

L : Louver or Damper Length.

H : Louver or Damper Height.

- Note : For quick selection, some selected sizes of Louvers I Dampers at specific Face Velocities (1.0 & 1.5 m/s) have been applied to the above equations and tabulated in the next two pages in the form of CFM values (table No.GL-01)

Engineering and Performance Data

Available Surface Finishes For Gravity Louvers:

- Natural I Matt Silver Anodized (Frame only).
- Powder Coating (Standard Colors are white RAL 901019016, other optional colors if required to be provided in RAL- No. only and charged extra).
- Aluminium in Mill Finish.
- Other Special Finishes (on request if available).

Available Surface Finishes For Non Return Dampers:

- Frame, only Galvanized steel sheet.
- Blades, only Aluminium Sheet in Mill Finish.

Ordering Specifications :

Specify:

1. Louver or Damper Description I Model (GL, NRD- s. Cor F).
2. Nominal I Neck size.
3. Quantity.
4. Surface Finish - for Gravity Louvers only.
5. RAL-No.-for Gravity Louvers only {only mention if powder coating surface finish is required}.
6. Type of Fixing- for Gravity Louvers only {Concealed or Face Screw Fixing}.
7. Rubber Gasket- for Gravity Louvers only {only mention if required}.

1	2	3	4	5	6	7
GL	10" x 10" 250 x 250 (mm)	15	Powder Coating	9010	Concealed	With Rubber Gasket

1	2	3	4	5	6	7
NRD-S	12" x 6" 300 x 150 (mm)	110	—	—	—	—

1	2	3	4	5	6	7
NRD-F	32" x 16" 800 x 400 (mm)	2	—	—	—	—



Notes

Dotted lines for note-taking.

Sand Trap Louvers

CONTENTS

- 01 Introduction, Features & Characteristics.
- 02 Models, Sand Trap Louvers.
- 03 Models, Flush Mounted Sand Trap Louvers.
- 04 Profiles used In Sand Trap Louvers.
- 05 Available Fixing Mounting.
- 06 Air Flow Resistance Diagram, Air Flow Rate Calculation.
- 07 Tabular Selection for Sand Trap Louvers.
- 08 Ordering Data.

➔ The Sand Trap Louvers STL of Global Air are designed for usage in serving as a Pre-Filter element in dusty and sandy zone conditions as well as to protect the entry to the external inlets of air conditioning or filtration ducting systems and walls. Blades are formed in U- Profiles placed alternately in vertical configuration. This particular configuration allows a sand and heavy

dust separation at high performance rates. The drain holes placed in the lower part let the Louver be self-emptying, self-cleaning and maintenance free.



➔ Features & Characteristics:

- The adjacent blades are positioned on 40 mm minimum spacing up to 60 mm maximum spacing providing maximum separation of sand or dust from inlet air at low air velocities, thus avoiding excessive dust loading of conventional filters.
- Construction: Frame & blades are made of high quality Extruded Aluminium Profiles of 6063 Alloy.
- Frame and Blades general wall thickness: 1.5- 1.8: mm and 1.2- 1.5 mm respectively.
- Frame Flange width: 20 mm.
- Blades width: 100 mm.
- The vertically U - Inverted blades are assembled in a double bank opposite style configuration which enables the unit to fulfill the requirements for not only a sand or dust filtration but also being a standard weather resisting assembly.
- Flush Mounted Sand Trap Louver type (Model FSTL) is also available. It's convenient to fix on the same plane of the wall with a sand chute tray fixed and inclined at the lower part of the Louver (suitable for all external wall installations).
- Since the STL is only a Pre-Filter unit, it's not recommended to be used alone in a system.
- The lower part of the Louver frame contains of 20 mm drain holes arranged in two parallel row for emptying the captured sand or dust.
- Available in wide variety of neck sizes with 150 x 150 mm minimum single section size and 2 mtr maximum single section height. Louvers height exceeding 2 mtr to be fabricated and supplied in multiple sections depending on length and height dimensions as well as site conditions.
- The assembly of multiple sections is unlimited where each section operates independently.
- Multiple sections: Supplied as separate sections and assembly by others on site.
- As a standard, the STL's are always provided with Bird Screen (Bird Guard) of galvanized steel with 12 x 12 mm grids attached behind the frame to prevent large flying objects and animals to pass through the system. Also available with Insect Screen as an option (on request).
-
- **Sand Trap Louvers are available with different type of attachments such as:**
 - -Aluminium Filter (Model STL + F).
 - -Opposed Blade Damper (Model STL +D).
 - -Both the Filter and Damper (Model STL + F +D).
 - Mounting instructions: see page No. SL-05.
 - Surface Finishes: see page No. SL-09.

Sand Trap Louvers

Construction and Dimensional Details

Model STL

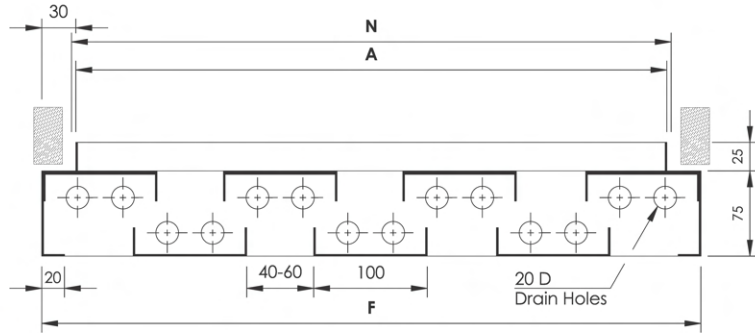

- Bird Screen (standard)

Model STL + F

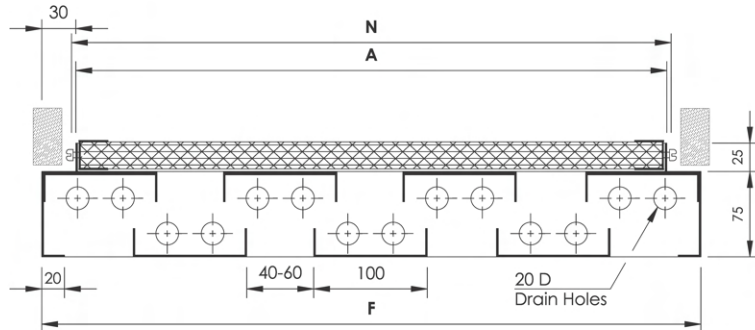
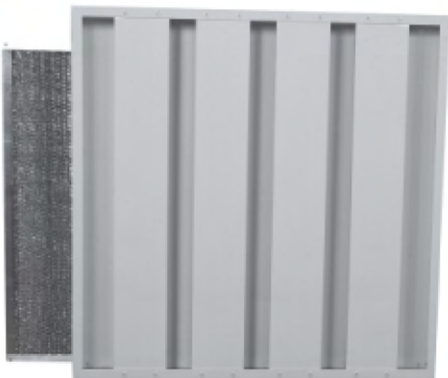

- Bird Screen (standard).
- Filter : Aluminium Washable Filter Media of 1/2 «

standard thickness (1 and 2 « thicknesses also available on request as an option).

N :Nominal/Listed Size = Length (L) x Height (H)
A :Actual Size = (L-5} x (H-5)
F :Face Size = (L+55) x (H+55)

- Sand Trap Louvers furnished approximately 5 mm less than the Nominal/Listed Size.
- All Dimensions are in mm and subject to ±1 mm tolerance.

Model STL + D

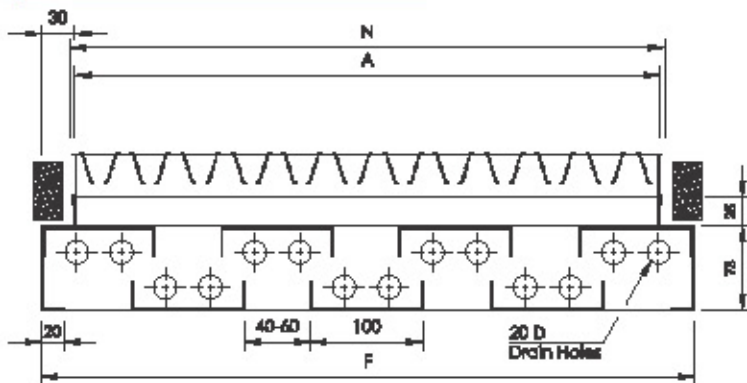

- Bird Screen (standard).
- For Opposed Blade Damper details and construction refer to chapter (1) or (2).
- For large sizes of STL it is not recommended to use this type of local Opposed Blade Damper due to its

weakness, thus for more rigidity the Opposed Blade Damper has to be replaced by Volume Control Damper (VCD).

Model STL + F + D

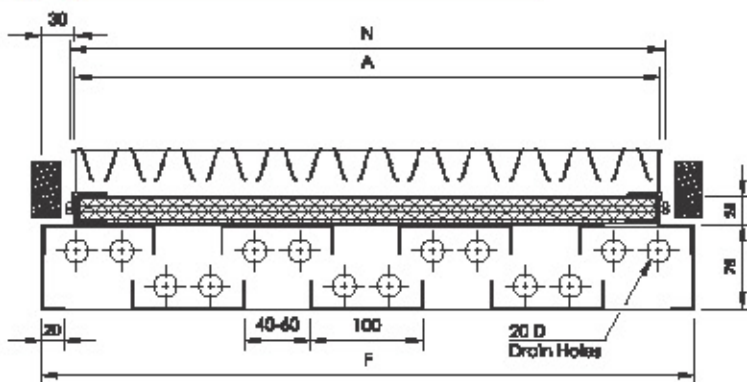

- Bird Screen (standard).
- Filter : Aluminium Washable Filter Media of 1 / 2 « standard thickness (1 and 2) thicknesses also

available on request as an option).

- For Opposed Blade Damper details and construction refer to chapter (1) or (2).

N : Nominal/Listed Size = Length (L) x Height (H)

A : Actual Size = (L-5) x (H-5)

F : Face Size = (L+55) x (H+55)

- Sand Trap Louvers furnished approximately 5 mm less than the Nominal/Listed Size.
- All Dimensions are in mm and subject to ± 1 mm tolerance.

Flush Mounted Sand Trap Louvers Construction and Dimensional Details

Model FSTL

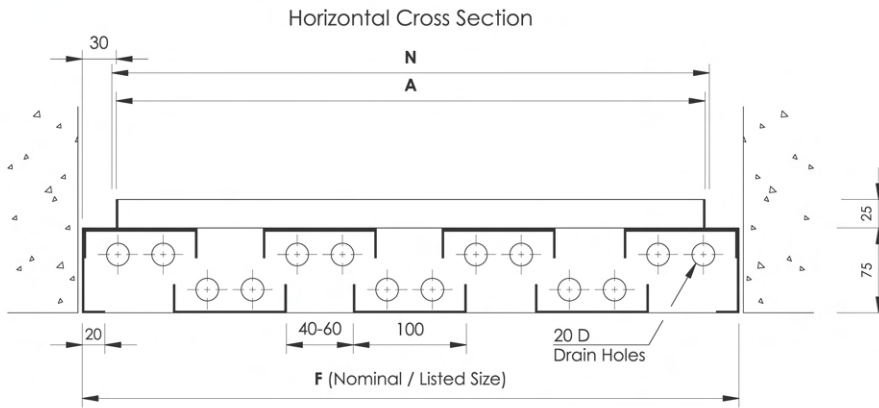

- Louver immersed inside the wall level.

- Bird Screen (standard).
- This model usually used when the Sand Trap louver is required to be installed in plane with the external wall of the building from outside.
- It's provided with especially designed sand chute tray as shown in order to ensure the discharge of captured sand or dust to outside the building.

- Also available with different Type of attachments such as:
 - Aluminium Aller (Model FSTL + F).
 - Opposed Blade Damper (Model FSTL + D).
 - Both the Riter and Damper (Model FSTL + F + D).
- As a unique case the sizing of this type of Louvers should be specified in outer frame dimensions i.e. the Face size
- will be treated as a Nominal/ Listed Size to fit the external wall opening as shown.

F : Nominal/ Listed Size (Face Size) = length (L) x Height (H)

A : Actual Size = (L-5) X (H-5)

N : Neck Size = (L-55) X (H-55)

- Flush Mounted Sand Trap Louvers furnished approximately 5 mm less than the Nominal/ Listed face size.
- All Dimensions are in mm and subject to ±0.1 mm tolerance.

➔ Cross Sectional Drawings for Profiles used in Sand Trap Louvers



frame Profile Section
Sand Trap Louvers

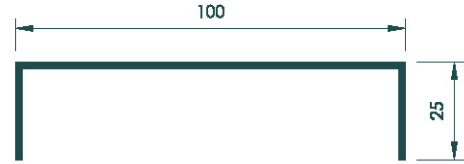

Blade Profile Section
Sand Trap Louvers

- All Dimensions are in mm and subject to ± 0.2 mm tolerance.

➔ Available Fixing Mounting

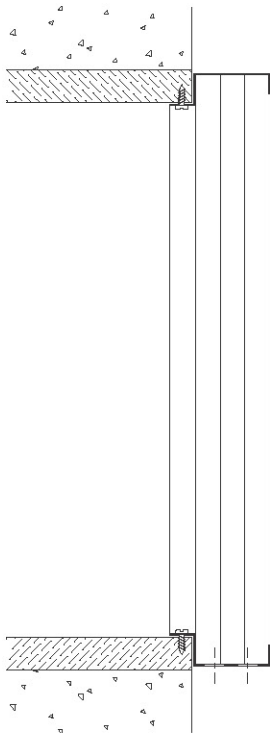

A. Screw Fixing (Fixing to wall)

Sand Trap Louver is fixed to the wall through its neck: by means of screws as shown.

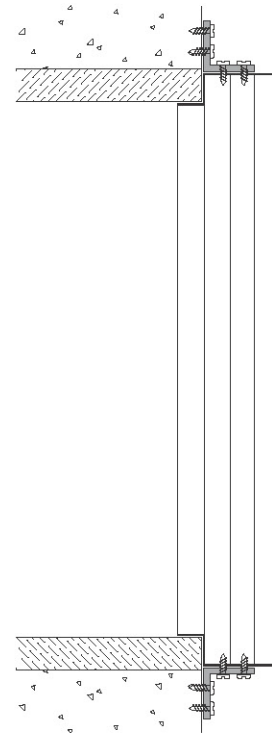

B. Angle Fixing (By Others)

For large sizes, it's recommended to use supporting Steel or Aluminium 90 a angle as shown above to reinforce holding of the louver by outside wall.

Air Flow Resistance Diagram (All Models) Pressure Drop (Pt), Efficiency (%) versus Face Velocity (Vt.)

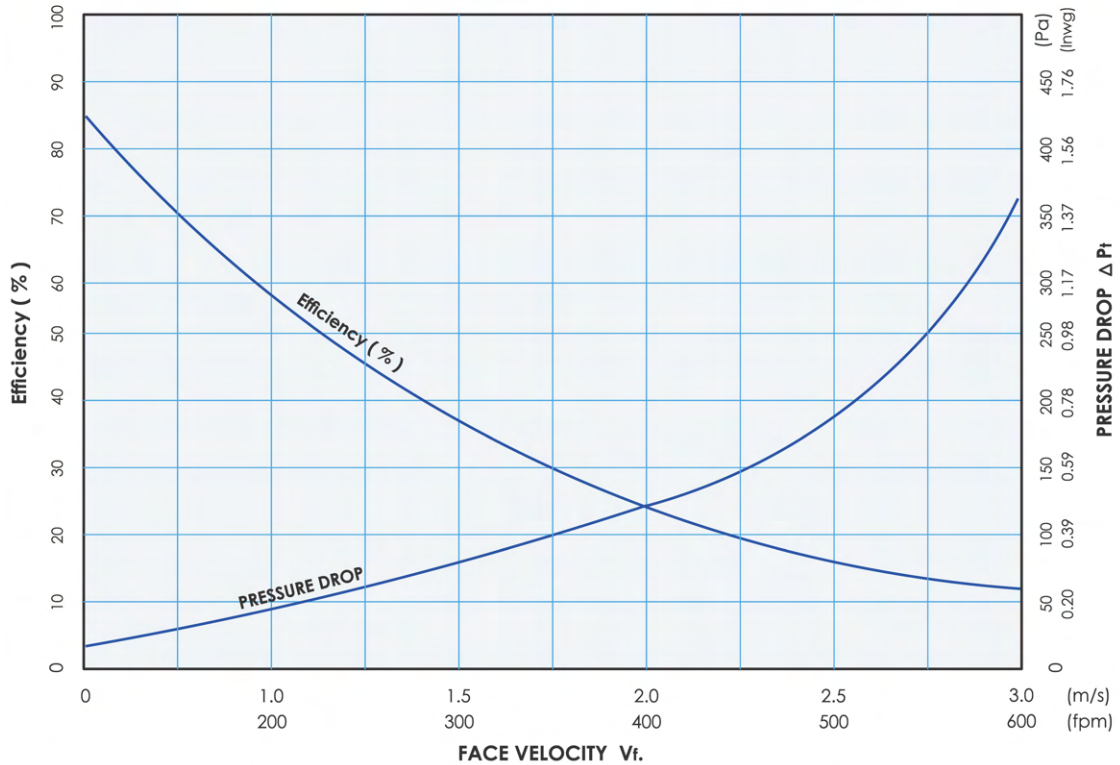

To Calculate The Air Flow Rate (All Models)

Simply the Air Flow Rate in (L/S) or (CFM) can be calculated using any of the following equations:

$$\text{Air Flow Rate In (L/S)} = 0.33 \frac{L \text{ (mm)} \times H \text{ (mm)} \times V r. \text{ (m/s)}}{100}$$

or

$$\text{Air Flow Rate In (CFM)} = 0.33 \frac{L \text{ (Inch)} \times H \text{ (Inch)} \times V r. \text{ (fpm)}}{151}$$

L : louver length.

H : Louver Height.

FiltraHon Efficiency :

The filtration performance is dependant on the dust type and the velocity of the air. thus :

Particle Size Range	FDtraHon Emclency In (%)	
	@ 1.0 m/s	@ 2.0 m/s
350 - 700	90	70
75 - 700	60	approx.30

For normal operation conditions, Sand Trap Louvers used for natural ventilation purpose ore rated at a recommended Face velocity not exceeding 1.0- 1.5 m/s.

Note : For quick selection, some selected sizes of Louvers at specific Face Velocities (1.0 & 1.5 m/s) have been applied to the above equations and tabulated in the next two pages in the form of CFM values {table No.SL-01 & 02} in order to cover your needs of sizing selection.

Ordering Data

➔ Available Surface Finishes For Sand Trap Louvers :

- Natural/ Matt Silver Anodized .
- Powder Coating (Standard Colors are white RAL 9010/ 9016, other optional colors if required to be provided in RAL- No.only and charged extra).
- Aluminium in Mill Finish.
- Other Special Finishes (on request if available) .

➔ Available Surface Finishes For Opposed Blade Damper:

- Aluminium in Mill Finish (standard).
- Matt Black Powder Coating (optional) .

➔ Ordering Specifications:

Specify:

1. Sand Trap Louver Description I Model (STL,STL+F,etc.).
2. Nominal/ Neck size.
3. Quantity.
4. Sand Trap Louvers Surface Finish.
5. RAL- No.(only mention if powder coating surface finish is required).
- 6.Thickness of Aluminium Filter for models attached with Filter (only mention if optional 1 or 2» thickness is required).

➔ Example 1:

1	2	3	4	5	6
STL	16" x 12" 400 x 300 (mm)	10	Powder Coating	9016	—

➔ Example 2:

1	2	3	4	5	6
STL + F + D	24" x 16" 600 x 400 (mm)	3	Mill Finish	—	2" (optional)

➔ Example 3:

1	2	3	4	5	6
FSTL + F	40" x 40" 1000 x 1000 (mm)	5	Powder Coating	7035 (optional)	1" (optional)



Global Air

Ajman / United Arab Emirates
P. O. Box: 3187 / Tel : +971 6 7432 020
Fax : +971 6 7432 030
Email: info.fabgpai@elitegroupuae.com

www.elitegroupuae.com